

Ratings and Certifications



Underwriters Laboratories. Class I, Groups C & D at 480 Vac, 60/400 Hz, Circuit-Breaking.



CSA International, U.S. and Canadian Standards: Class I, Groups B, C & D and Class II, Groups F & G at 600 Vac, 60/400 Hz, Circuit-Breaking.



0344 II 2 G D, EEx d IIC T6; -20°C ≤ Ta ≤ +50°C; IP 66/67 T70°. For Standard and Reverse Service, 50/60/400 Hz; 500 Vdc, 1000 Vac.

Operation

Receptacles are mated to plugs that feature a quick make and break design. To engage, align plug to receptacle and turn coupling sleeve clockwise. Plug will be injected automatically & close circuit. Continue turning coupling sleeve to solid to provide environmental seal. To disengage, rotate coupling sleeve c.c.w. (counterclockwise). Plug will eject automatically. Continue turning coupling sleeve to extract the plug. **Caution:** Do not interfere with cable housing. To prevent shock hazard the receptacle cover must be threaded onto receptacle when receptacle is not in use.

Materials (See Tables 5, and 6 for Material Composition data)

GD Series, Wrought Aluminum 6061-T6, copper-free, with Hardcoating per Mil-A-8625 Type III, black finish.
SD Series, Stainless Steel Type 316.

Assembly

Receptacles are designed for field termination. Wire leads can be spliced or landed to terminals. No special tools are required.

Maintenance

Periodic maintenance consists of inspection for termination integrity and contamination. When conditions require, lubricate coupling threads with silicone oil, Vantage Part Number VT-9400-21D.

Before Ordering

Insert: Table 4 lists the available insert configurations. The insert selection dictates the shell size of the plug. Diagrams are available for each insert configuration, request document PDS-GD-SD-INSERTS. Pins and sockets are available in several finishes, see Table 3.

NPT Thread Size: Note that the NPT mounting thread size varies with the connector shell size. See Dimension Table 1 for sizes.

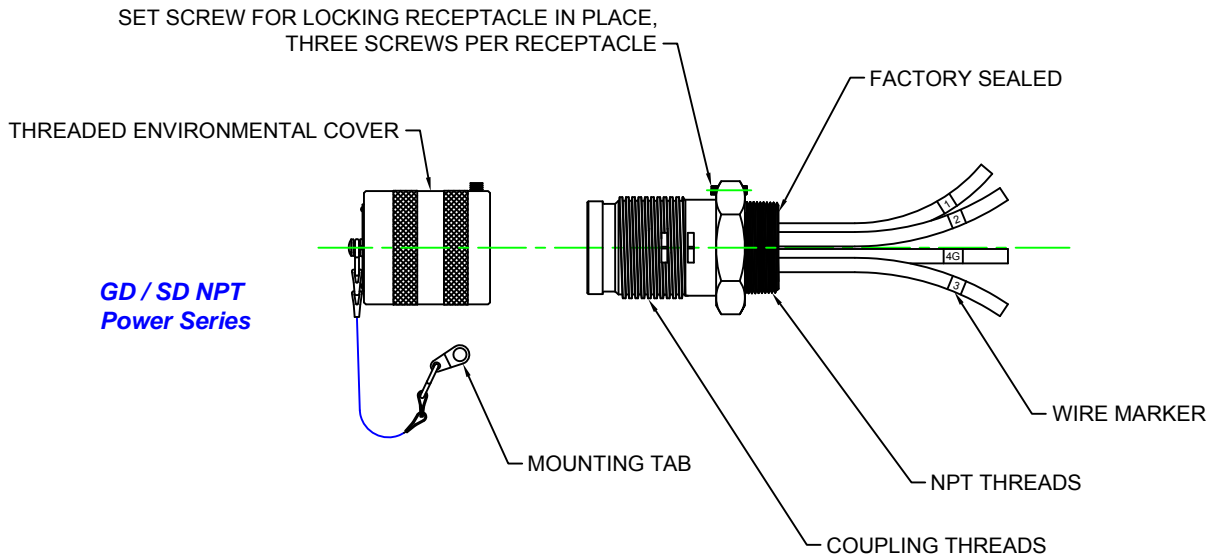

REVISION: B	WTN BY: JOHN NORDECK	TITLE: GD AND SD NPT MOUNT RECEPTACLES	Vantage Technology LLC 4875 South Windermere Street Englewood, Colorado USA 80110 Phone: 303-781-2121 FAX: 303-789-4215 Email: support@vantagexp.com
	CHK BY: DARRIN LOMBARD		
	ENG BY:		
	ATEX: JOHN NORDECK		
	ISSUE DATE: JULY 27, 2005		
PRODUCT DATA SHEET		DOCUMENT: PDS-GD-SD-NPT	SHEET: 1 OF 4

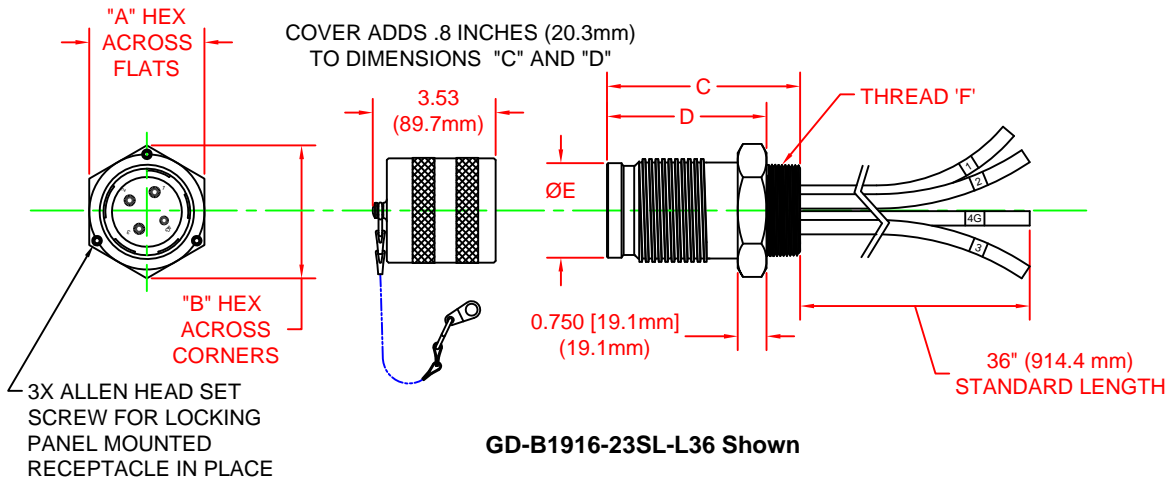

SHELL SIZE	TABLE 1: DIMENSIONS, LENGTH IN INCHES (mm) AND WEIGHT IN LBS (kg)						
	A	B	C	D	E	F - NPT THREAD	WEIGHT (1)
16	2.5 (63.5)	2.875 (73.0)	5 (127.0)	4.156 (105.6)	1.969 (50.0)	1 1/2 - 11½	3 (1.4)
20	3 (76.2)	3.469 (88.1)	5.031 (127.8)	4.156 (105.6)	2.469 (62.7)	2 - 11½	5 (2.3)
24	3.5 (88.9)	4.031 (102.4)	5.406 (137.3)	4.156 (105.6)	2.969 (75.4)	2 1/2 - 8	8 (3.6)
28	4 (101.6)	4.625 (117.5)	5.469 (138.9)	4.156 (105.6)	3.469 (88.1)	3 - 8	13 (5.9)

(1) MULTIPLY WEIGHT BY 1.4 FACTOR TO CALCULATE WEIGHT OF STAINLESS STEEL VERSION (SD).

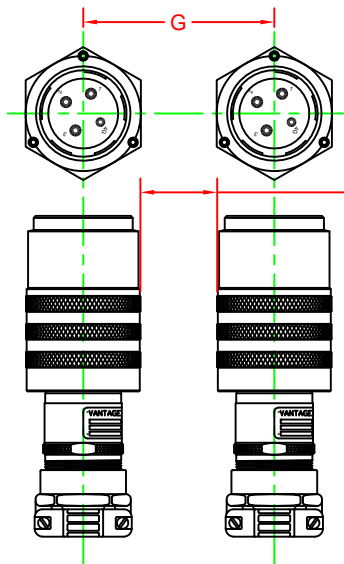

WHEN MOUNTING TWO OR MORE RECEPTACLES TO AN ENCLOSURE, IT IS RECOMMENDED THAT 2 INCHES OF SPACING BE ALLOWED TO PROVIDE SUFFICIENT ACCESS FOR ROTATION OF PLUG COUPLING SLEEVE. SEE TABLE 2 FOR MOUNTING CENTERS.

SHELL SIZE	TABLE 2: RECEPTACLE MOUNTING SPACING	
	G IN INCHES (mm)	
16	5.0 (127)	FOR MIXED SHELL SIZES, ADD DIMENSION "G" FOR EACH AND DIVIDE BY TWO.
20	5.6 (142)	
24	6.2 (158)	
28	6.8 (173)	



WTN BY: JOHN NORDECK
CHK BY: DARRIN LOMBARD
ISSUE DATE: JULY 27, 2005

TITLE:
GD AND SD NPT
MOUNT RECEPTACLES
PRODUCT DATA SHEET

REVISION: B
DOCUMENT: PDS-GD-SD-NPT
SHEET: 2 OF 4

TABLE 3: NPT MOUNT RECEPTACLE PART NUMBER CODE LOGIC											
GD	-	B	19	16	-	23	S	L	01	-	L36
1		2	3	4		5	6	7	8		9

1	CLASSIFICATION	GD = ALUMINUM SD = STAINLEES STEEL
2	COVER	B = RECEPTACLE COVER
3	SHELL STYLE	19= RECEPTACLE, NPT MOUNT
4	SHELL SIZE	16 = SHELL SIZE 16 24 = SHELL SIZE 24 20 = SHELL SIZE 20 28 = SHELL SIZE 28
5	INSERT	SEE INSERT TABLE, TABLE 4
6	GENDER	P = MALE (PIN) INSERT S = FEMALE (SOCKET) INSERT
7	CONTACT PLATING	L = SILVER PLATE (STANDARD) GROUND CONTACTS ARE GOLD OVER SILVER
8	INSERT KEYING	SEE VANTAGE INSERT PRODUCT DATA SHEET, PDS-GD-SD-INSERT
9	WIRE LENGTH	LENGTH OF WIRES IN INCHES 36 INCHES STANDARD LENGTH

TABLE 4: INSERTS AND AMPERE RATINGS								
CONTACTS	AMPERES			CONNECTOR PREFIX	SHELL SIZE	INSERT CODE NUMBER		KEY POSITIONS
						PIN	SOCKET	
2 POLE, 3 WIRE	30	30	32	GD or SD	16	51PL	51SL	N + 5
3 POLE, 4 WIRE	30	30	32	GD or SD	16	23PL	23SL	N + 5
4 POLE, 5 WIRE	30	30	32	GD or SD	20	36PL	36SL	N + 2
2 POLE, 3 WIRE	60	60	63	GD or SD	20	61PL	61SL	N + 7
3 POLE, 4 WIRE	60	60	63	GD or SD	20	40PL	40SL	N + 4
4 POLE, 5 WIRE	60	60	63	GD or SD	24	29PL	29SL	N + 3
2 POLE, 3 WIRE	100	100	125	GD or SD	24	60PL	60SL	N + 7
3 POLE, 4 WIRE	100	100	125	GD or SD	24	39PL	39SL	N + 5
4 POLE, 5 WIRE	100	100	125	GD or SD	28	23PL	23SL	N + 3
2 POLE, 3 WIRE	200	200	260	GD or SD	28	30PL	30SL	N + 9
3 POLE, 4 WIRE	200	200	260	GDU or SDU	28	31PL	31SL	N + 10
5 POLE, 6 WIRE	200	200	260	GDT or SDT	28	42PL	42SL	N + 3

WTN BY: JOHN NORDECK	TITLE: GD AND SD NPT MOUNT RECEPTACLES PRODUCT DATA SHEET	REVISION: B
CHK BY: DARRIN LOMBARD		DOCUMENT: PDS-GD-SD-NPT
ISSUE DATE: JULY 27, 2005		SHEET: 3 OF 4

ELEMENTAL COMPOSITIONS

TABLE 5: ELEMENTAL COMPOSITION OF ALUMINUM 6061-T6 PERCENTAGE BY WEIGHT											
	Al	Cr	Cu	Fe	Mg	Mn	Si	Ti	Zn	Other Each	Other Total
MIN	REM	0.04	0.15	-	0.80	-	0.40	-	-	-	-
MAX	REM	0.35	0.40	0.70	1.20	0.15	0.80	0.15	0.25	0.05	0.15

TABLE 6: ELEMENTAL COMPOSITION OF STAINLESS STEEL TYPE 316 PERCENTAGE BY WEIGHT											
	Fe	C	Mn	Si	P	S	Cr	Mo	Ni	N	Other
MIN	REM	-	-	-	0	-	16.0	2.0	10.0	-	-
MAX	REM	0.08	2.0	0.75	0.045	0.03	18.0	3.0	14.0	0.10	-