





Ratings and Certifications

 0344  II 2 G D, EEx d IIC T6, KEMA 04ATEX2179 X; -20°C ≤ Ta ≤ +50°C; IP 66/67 T70°C.  
For Standard and Reverse Service, 50/60/400 Hz, 250 Vac/125Vdc.

 CSA International, U.S. and Canadian Standards: Class I, Division 1, Groups B, C & D and Class II, Division 1, Groups F & G for Standard and Reverse Service, 60 Hz, 250 Vac. Select inserts are rated at 480 Vac non-circuit breaking.

Operation

Receptacles are mated to plugs that feature a quick make and break design. To engage, align plug to receptacle and turn coupling sleeve clockwise. Plug will be injected automatically & close circuit. Continue turning coupling sleeve to solid to provide environmental seal. To disengage, rotate coupling sleeve c.c.w (counterclockwise). Plug will eject automatically. Continue turning coupling sleeve to extract the plug. **C** : Do not interfere with cable housing. To prevent shock hazard the receptacle cover must be threaded onto receptacle when receptacle is not in use.

Materials (See Tables 5 and 6 for Material Composition data)

AF Series, Wrought Aluminum 6061-T6, copper-free, with Hardcoating per Mil-A-8625 Type III, black finish.  
SF Series, Stainless Steel Type 316.

Assembly

Attachment receptacles are designed for field termination. Vantage crimp tool T-104 insures properly and safely crimped contacts to conductors. Assembly instructions are included. A vise, strap wrench, and blade screw driver are required.

Maintenance

Periodic maintenance consists of inspection for termination integrity and contamination. When conditions require, lubricate coupling threads with silicone oil, Vantage Part Number VT-9400-21D.

Before Ordering

Insert: Table 3 lists the available insert configurations. The insert selection dictates the shell size of the receptacle. Diagrams are available for each insert configuration, request Vantage Insert Product Data Sheet. Pins and sockets are available in several finishes, see Table 2.

Grommet: To provide safe environmental sealing, a correctly sized grommet must be selected. Reference Table 4 to determine grommet code.

Options: Attachment receptacles come standard with a mechanical clamp nut. Options include a basket weave grip or a NPT threaded conduit backshells. Table 7 lists the available NPT sizes for each shell size.

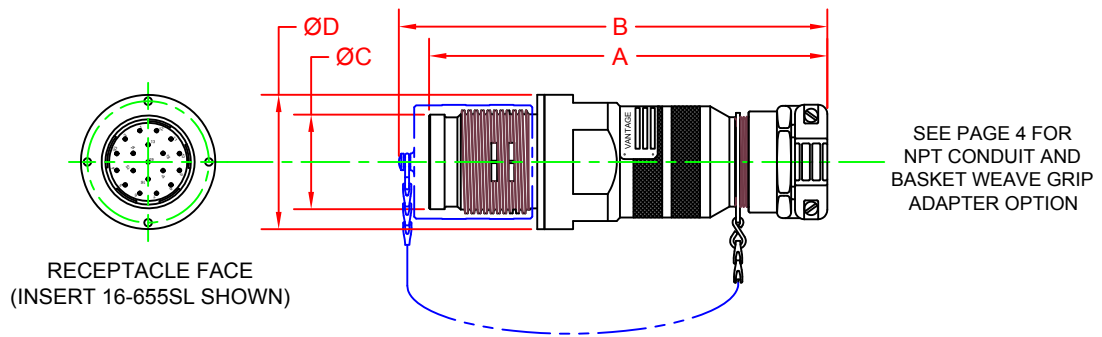



SHELL SIZE	DIMENSION IN INCHES (mm)			
	A	B	C	D
16	10.0 (254)	11.8 (300)	1.969 (50.0)	3.063 (77.8)
20	10.7 (272)	12.5 (317)	2.468 (62.7)	3.563 (90.5)
24	11.1 (283)	12.9 (328)	2.969 (75.4)	4.188 (106.4)
28	11.4 (291)	13.2 (336)	3.468 (88.1)	4.688 (119.1)

<b>REVISION:</b>	WTN BY: JOHN NORDECK	<b>TITLE:</b> AF AND SF ATTACHMENT RECEPTACLES	 <b>Vantage Technology LLC</b>	4875 South Windermere Street Englewood, Colorado USA 80110 Phone: 303-781-2121 FAX: 303-789-4215 Email: service@vantagexp.com
	CHK BY: DARRIN LOMBARD			DOCUMENT: PDS-AF-SF-ATR
	ENG BY:			SHEET: 1 OF 4
	ATEX: JOHN NORDECK			
ISSUE DATE: AUGUST 14, 2004	<b>PRODUCT DATA SHEET</b>			

TABLE 2: ATTACHMENT RECEPTACLE PART NUMBER CODE LOGIC														
AF	-	B	15	16	-	655	S	L	01	-	XX			
1		2	3	4		5	6	7	8		9			
1	CLASSIFICATION		AF = ALUMINUM SF = STAINLEES STEEL											
2	COVER		B = RECEPTACLE COVER											
3	SHELL STYLE		15 = RECEPTACLE, ATTACHMENT											
4	SHELL SIZE		16 = SHELL SIZE 16			24 = SHELL SIZE 24			20 = SHELL SIZE 20			28 = SHELL SIZE 28		
5	INSERT		SEE INSERT TABLE, TABLE 3											
6	GENDER		S = FEMALE (SOCKET) INSERT P = MALE (PIN) INSERT											
7	CONTACT PLATING		L = SILVER PLATE (STANDARD) K = GOLD OVER SILVER D = GOLD OVER NICKLE											
8	INSERT KEYING		SEE VANTAGE INSERT PRODUCT DATA SHEET											
9	ACCESSORY		XX = CABLE DIAMETER CODE, SEE TABLE 4 TC = TAPPED CONDUIT, SEE TABLE 5 B = BASKET WEAVE GRIP, INSERT AFTER 'XX'											

TABLE 3: INSERT TABLE AND AMPERE RATINGS						
CONTACT QUANTITY	CONTACT SIZE (mm <sup>2</sup> )	CONNECTOR PREFIX	SHELL SIZE	INSERT CODE NUMBER		KEY POSITIONS
				PIN	SOCKET	
10	12 (4.0)	AF or SF	16	681PL	681SL	N + 4
10	12 / G (4.0)	AF or SF	16	676PL	676SL	N + 1
19	12 / G (4.0)	AF or SF	16	612PL	612SL	N + 4
19	12 (4.0)	AF or SF	16	677PL	677SL	N + 1
19	12 (4.0)	AF or SF	20	676PL	676SL	N + 4
19	12 / G (4.0)	AF or SF	20	688PL	688SL	N
19	16 (1.5)	AF or SF	16	655PL	655SL	N + 9
20	12 (4.0)	AF or SF	20	632PL	632SL	N + 3
20	12 / G (4.0)	AF or SF	20	687PL	687SL	N + 1
37	12 (4.0)	AF or SF	20	686PL	686SL	N
37	12 / G (4.0)	AF or SF	20	650PL	650SL	N + 3
37	16 (1.5)	AF or SF	16	621PL	621SL	N + 9
55	18 (0.75)	AF or SF	16	640PL	640SL	N + 10
61	18 (0.75)	AF or SF	16	633PL	633SL	N + 4
68	16 (1.5)	AF or SF	20	613PL	613SL	N + 4
100	16 (1.5)	AF or SF	24	613PL	613SL	N + 4

CONTACT SIZE (mm <sup>2</sup> )	 AMPERE RATING 250 Vac, 60 Hz <sup>1</sup>	 AMPERE RATING 250 Vac / 125 Vdc, 50/60/400 Hz
18 (0.75)	3.5	10
16 (1.5)	6.5	15
12 (4.0)	10.0	20
10 (6.0)	10.0	30

1. Insert Codes VT-20-676 and VT-20-688 are also rated at 480 Vac Non-circuit Breaking.

WTN BY: JOHN NORDECK	TITLE: AF AND SF ATTACHMENT RECEPTACLES	REVISION: C
CHK BY: DARRIN LOMBARD	<b>PRODUCT DATA SHEET</b>	DOCUMENT: PDS-AF-SF-ATR
ISSUE DATE: AUGUST 14, 2004		SHEET: 2 OF 4

TABLE 4: CABLE DIAMETER GROMMET CODES						
CODE NUMBER	CABLE DIAMETER INCHES (mm)		SHELL SIZE			
	MINIMUM	MAXIMUM	16	20	24	28
06	0.250 (6.35)	0.375 (9.53)	X			
08	0.375 (9.53)	0.500 (12.70)	X			
10	0.500 (12.70)	0.625 (15.88)	X	X		
12	0.625 (15.88)	0.750 (19.05)	X	X		
14	0.750 (19.05)	0.875 (22.23)	X	X		
16	0.875 (22.23)	1.000 (25.40)	X	X	X	
18	1.000 (25.40)	1.125 (28.58)	X	X	X	
20	1.125 (28.58)	1.250 (31.75)	X	X	X	
22	1.250 (31.75)	1.375 (34.93)	X	X	X	
23	1.375 (34.93)	1.437 (36.50)	X	X	X	
24	1.375 (34.93)	1.500 (38.10)		X	X	X
26	1.500 (38.10)	1.625 (41.28)		X	X	X
28	1.625 (41.28)	1.750 (44.45)		X	X	X
30	1.750 (44.45)	1.875 (47.63)		X	X	X
31	1.875 (47.63)	1.937 (49.20)		X	X	X
32	1.875 (47.63)	2.000 (50.80)			X	X
34	2.000 (50.80)	2.125 (53.98)			X	X
36	2.125 (53.98)	2.250 (57.15)			X	X
38	2.250 (57.15)	2.375 (60.33)			X	X
39	2.375 (60.33)	2.437 (61.90)			X	X
40	2.375 (60.33)	2.500 (63.50)				X
42	2.500 (63.50)	2.625 (66.68)				X
44	2.625 (66.68)	2.750 (69.85)				X
46	2.750 (69.85)	2.875 (73.03)				X

**ELEMENTAL COMPOSITIONS**

TABLE 5: ELEMENTAL COMPOSITION OF ALUMINUM 6061-T6 PERCENTAGE BY EIGHT											
	Al	Cr	Cu	Fe	Mg	Mn	Si	Ti	Zn	Other Each	Other Total
<b>MIN</b>	REM	0.04	0.15	-	0.80	-	0.40	-	-	-	-
<b>MAX</b>	REM	0.35	0.40	0.70	1.20	0.15	0.80	0.15	0.25	0.05	0.15

TABLE 6: ELEMENTAL COMPOSITION OF STAINLESS STEEL TYPE 316 PERCENTAGE BY EIGHT											
	Fe	C	Mn	Si	P	S	Cr	Mo	Ni	N	Other
<b>MIN</b>	REM	-	-	-	0	-	16.0	2.0	10.0	-	-
<b>MAX</b>	REM	0.08	2.0	0.75	0.045	0.03	18.0	3.0	14.0	0.10	-

WTN BY: JOHN NORDECK	TITLE: AF AND SF ATTACHEMT RECEPTACLES  <b>PRODUCT DATA SHEET</b>	REVISION: C
CHK BY: DARRIN LOMBARD		DOCUMENT: PDS-AF-SF-ATR
ISSUE DATE: AUGUST 14, 2004		SHEET: 3 OF 4

TABLE 7: TAPPED CONDUIT ATTACHMENT RECEPTACLE			
SHELL SIZE	THREAD 'A'	E IN INCHES (mm)	F IN INCHES (mm)
16	1 1/4 -11 1/2 NPT	9.5 (241)	11.3 (287)
20	1 1/2 -11 1/2 NPT	10.2 (259)	12.0 (305)
24	2 -11 1/2 NPT	10.6 (269)	12.4 (315)
28	2 1/2 - 8 NPT	10.9 (277)	12.7 (323)

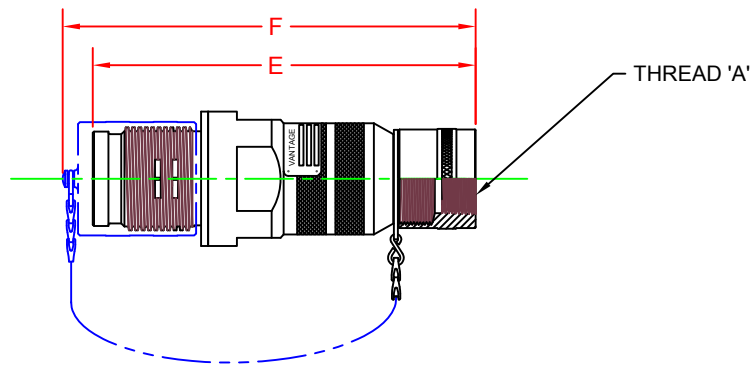
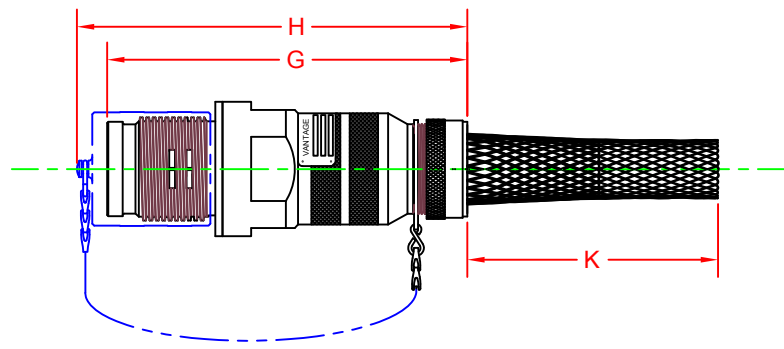

TABLE 8: BASKET WEAVE ATTACHMENT RECEPTACLE			
SHELL SIZE	G IN INCHES (mm)	H IN INCHES (mm)	K IN INCHES (mm)
16	10.0 (254)	11.8 (300)	3.75 - 10.25 (95 - 260)
20	10.7 (272)	12.5 (317)	5.75 - 14.25 (146 - 362)
24	11.1 (283)	12.9 (328)	8.25 - 17.25 (210 - 438)
28	11.4 (291)	13.2 (336)	13.75 - 19.75 (349 - 502)



NOTE: UL 1010, *Receptacle-Plug Combinations for Use in Hazardous (Classified) Locations*, REQUIRES THE USE OF A MECHANICAL CORD CLAMP OR STRAIN RELIEF ON CABLE ATTACHMENT CONNECTORS. CONNECTORS WITH BASKET WEAVE GRIPS ARE AVAILABLE WITH CSA AND ATEX CERTIFICATION.

WTN BY: JOHN NORDECK	TITLE: AF AND SF ATTACHMENT RECEPTACLES	REVISION: C
CHK BY: DARRIN LOMBARD	<b>PRODUCT DATA SHEET</b>	DOCUMENT: PDS-AF-SF-ATR
ISSUE DATE: AUGUST 14, 2004		SHEET: 4 OF 4