

Attachment Plugs

GB/SB and GD/SD Series

ASSEMBLY, TERMINATING and USAGE INSTRUCTIONS

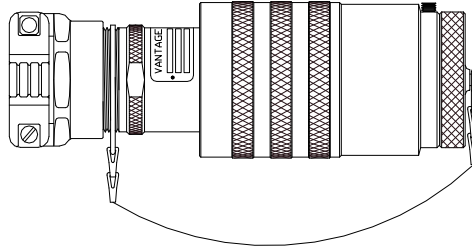

GB/SB AND GD/SD SERIES ATTACHMENT PLUGS



Recapitulation of Equipment Marking

Catalog Number 1	480 VOLT 643A	5 C-D
AMPS UL-CSA 2	UL 480V CSA 600V Hz 60/400 AMPS ATEX 3	HAZARDOUS LOCATIONS CLASS I, GROUP 5 C-D
For use with Receptacle 4	LISTED PLUG	CAUTION: To engage, align plug to receptacle and turn coupling sleeve clockwise. Plug will be injected automatically & close circuit. Continue turning coupling sleeve to solid to provide environmental seal. To disengage, rotate coupling sleeve c.c.w. Plug will eject automatically. Continue turning coupling sleeve to extract the plug. Caution: Do not interfere with cable housing.
EEEx d IIC T6 KEMA 04ATEX2179 X IP66/67 T70°C -20°C = Ta = +50°C	Class I Zone 1 AEx d IIC, T6 Ex d IIC, T6	DO NOT SEPARATE WHEN ENERGIZED - NE PAS OUVRIR SOUS TENSION
0575 II 2 G D	600 VOLT	VANTAGE TECHNOLOGY ENGLEWOOD, COLORADO 80110, U.S.A. MFG CODE 6

EQUIPMENT NAMEPLATE

Field 1 Catalog Number ¹	Field 2 AMP Rating	Field 3 AMP Rating	Field 4 For use with Receptacle ²	Field 5 Group(s)
	 			
GB-1016-51PL-XX	30	32	GB-B1716-51SL-AG	B-C-D
GD-1016-51PL-XX	30	32	GD-B1716-51SL-AG	C-D
GB-1016-23PL-XX	30	32	GB-B1716-23SL-AG	B-C-D
GD-1016-23PL-XX	30	32	GD-B1716-23SL-AG	C-D
GB-1020-36PL-XX	30	32	GB-B1720-36SL-AH	B-C-D
GD-1020-36PL-XX	30	32	GD-B1720-36SL-AH	C-D
GB-1020-61PL-XX	60	63	GB-B1720-61SL-AG	B-C-D
GD-1020-61PL-XX	60	63	GD-B1720-61SL-AG	C-D
GB-1020-40PL-XX	60	63	GB-B1720-40SL-AH	B-C-D
GD-1020-40PL-XX	60	63	GD-B1720-40SL-AH	C-D
GB-1024-29PL-XX	60	63	GB-B1724-29SL-BJ	B-C-D
GD-1024-29PL-XX	60	63	GD-B1724-29SL-BJ	C-D
GB-1024-60PL-XX	100	125	GB-B1724-60SL-BH	B-C-D
GD-1024-60PL-XX	100	125	GD-B1724-60SL-BH	C-D
GB-1024-39PL-XX	100	125	GB-B1724-39SL-BK	B-C-D
GD-1024-39PL-XX	100	125	GD-B1724-39SL-BK	C-D
GB-1028-23PL-XX	100	125	GB-B1728-23SL-BL	B-C-D
GD-1028-23PL-XX	100	125	GD-B1728-23SL-BL	C-D
GB-1028-30PL-XX	-	260	GB-B1728-30SL-BL	B-C-D
GD-1028-30PL-XX	200	260	GD-B1728-30SL-BL	C-D
GB-1028-31PL-XX	-	260	GB-B1728-31SL-BL	B-C-D
GDU-1028-31PL-XX	200	260	GDU-B1728-31SL-BL	C-D
GDT-1028-42PL-XX	200	260	GDT-B1728-42SL-BL	C-D

- Part numbers may vary; consult Vantage with questions. An SB or SD prefix indicates the stainless steel version. Occurrence of the letter 'D' represents the addition of a cover. An 'SL' instead of 'PL' represents sockets instead of pins. Characters such as 'PL01' represent that the insert is keyed in the '01' key position and will only mate with inserts with the same orientation. Substitute the 'XX' with the cable diameter code on page 4.
- Part numbers may vary; consult Vantage with questions. An SB or SD prefix indicates the stainless steel version. A 'PL' instead of 'SL' represents pins instead of sockets. Characters such as 'SL01' represent that the insert is keyed in the '01' key position and will only mate with inserts with the same orientation. The suffix represents the size and location of the conduit/gland openings.

IDENTIFICATION OF PRINCIPAL PARTS

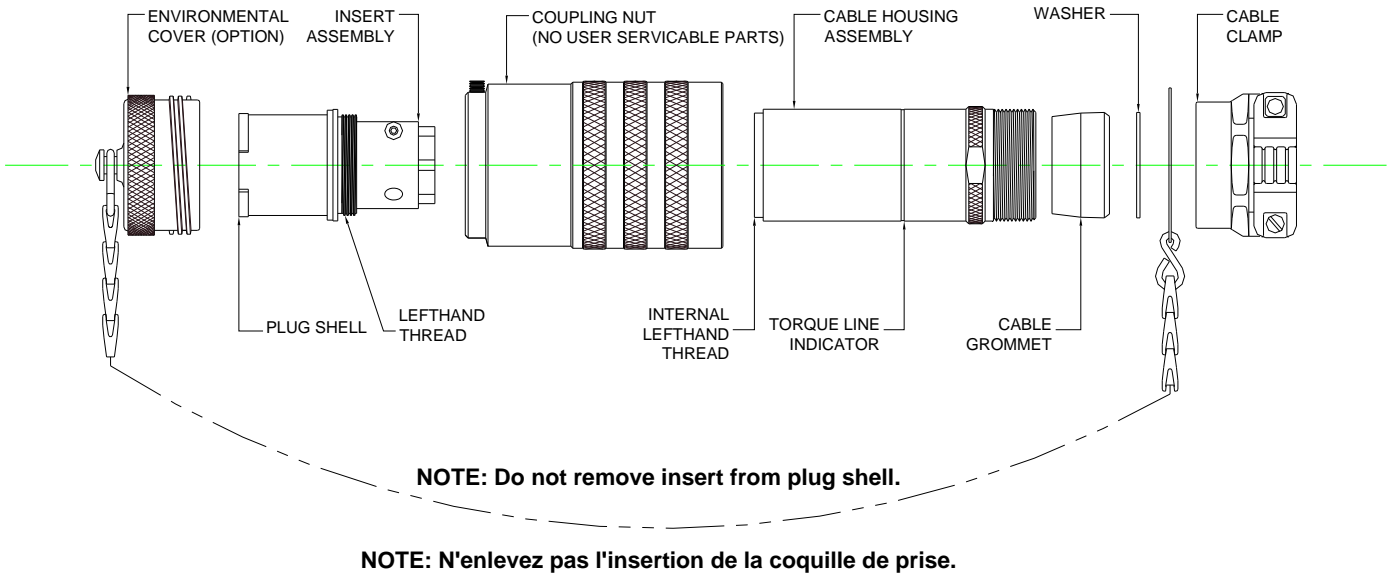

STEP 1 - PREPARING TO ASSEMBLE

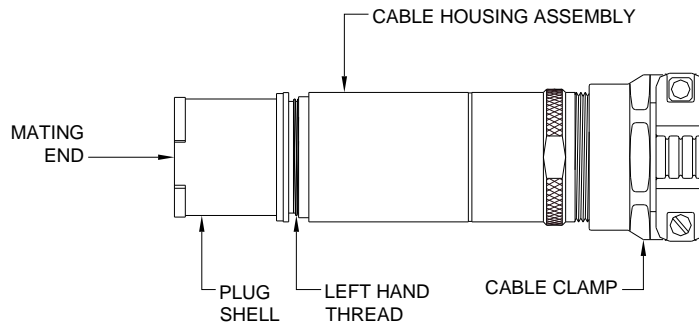

STEP 1A

DISASSEMBLE PLUG SHELL-INSERT ASSEMBLY FROM CABLE HOUSING ASSEMBLY

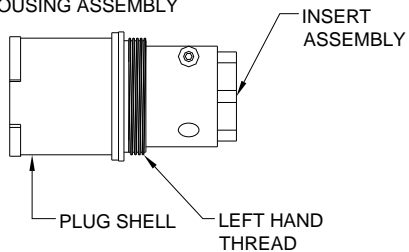

STEP 1B

DISASSEMBLE CABLE CLAMP AND ASSOCIATED COMPONENTS FROM CABLE HOUSING ASSEMBLY.

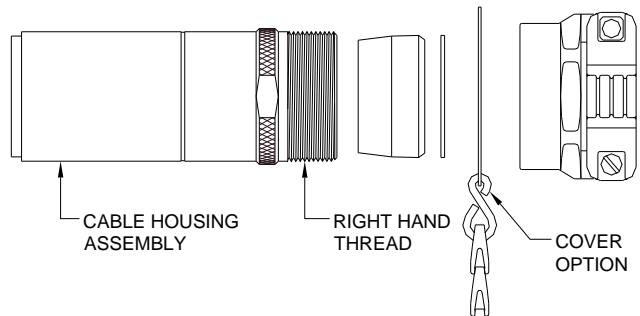

NOTE: Do not remove insert from plug shell.
NOTE: N'enlevez pas l'insertion de la coquille de prise.

GROMMET SELECTION

It is important that a properly sized grommet has been selected to obtain a good environmental seal. Failure to provide proper environmental sealing can permit moisture or other conductive material to enter the connector resulting in possible electrical failure.

Please use the table on page 4 to confirm that the grommet ordered fits your cable properly. If not, please contact us for an immediate grommet replacement.

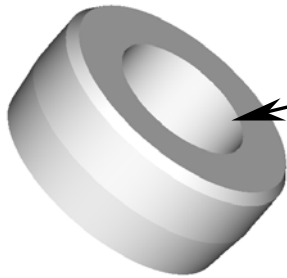

Grommet I.D. must fit cable O.D. range.

**CAUTION!
ATTENTION!**

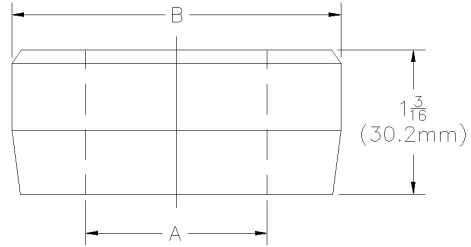

Dimension A = Max. Cable Diameter
Dimension B varies with Shell Size

STEP 2 - ASSEMBLY OF BACKSHELL COMPONENTS

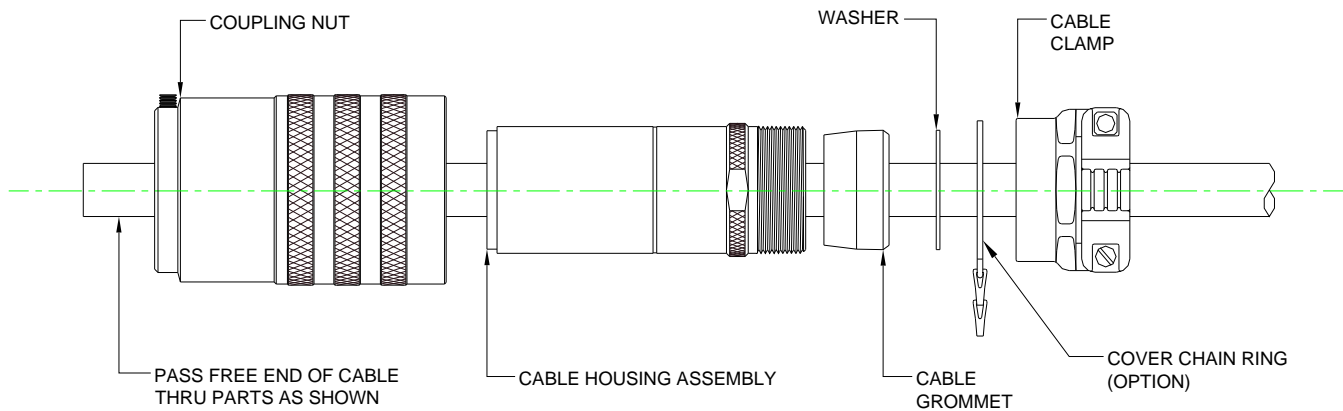

STEP 3 - CABLE JACKET & WIRE STRIPPING

Strip cable jacket 3" (76.2mm) as shown. Select dimension "A" from table to correspond with connector rating and strip conductors. The connector's rating can be found on the plug's nameplate.

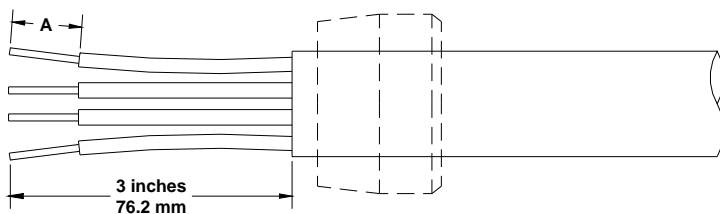

CONTACT SIZE (AMPS)	DIM. A	
	INCHES	mm
30	13/16	20.6
60	1 11/32	34.1
100	1 3/8	34.9
200	1 15/32	37.3

NOTE: The cable should be free of grooves or ridges in the area where the cable grommet seats on the cable. Also, be sure that the correct grommet size has been ordered to fit cable.

Grommet Table

Shell Size	Dim. B	Cable Diameter				Cable Diameter Code Number*	Grommet Part Number
		MIN.		MAX., Dim. A			
		inches	mm	inches	mm		
16	1 23/32 inches 43.7 mm	.250	6.4	.375	9.5	06	VT-6316-6C
		.375	9.5	.500	12.7	08	VT-6316-8C
		.500	12.7	.625	15.9	10	VT-6316-10C
		.625	15.9	.750	19.1	12	VT-6316-12C
		.750	19.1	.875	22.2	14	VT-6316-14C
		.875	22.2	1.000	25.4	16	VT-6316-16C
		1.000	25.4	1.125	28.6	18	VT-6316-18C
		1.125	28.6	1.250	31.8	20	VT-6316-20C
		1.250	31.8	1.375	34.9	22	VT-6316-22C
		1.375	34.9	1.437	36.5	23	VT-6316-23C
20	2 7/32 inches 56.4 mm	.500	12.7	.625	15.9	10	VT-6320-10C
		.625	15.9	.750	19.1	12	VT-6320-12C
		.750	19.1	.875	22.2	14	VT-6320-14C
		.875	22.2	1.000	25.4	16	VT-6320-16C
		1.000	25.4	1.125	28.6	18	VT-6320-18C
		1.125	28.6	1.250	31.8	20	VT-6320-20C
		1.250	31.8	1.375	34.9	22	VT-6320-22C
		1.375	34.9	1.500	38.1	24	VT-6320-24C
		1.500	38.1	1.625	41.3	26	VT-6320-26C
		1.625	41.3	1.750	44.5	28	VT-6320-28C
24	2 23/32 inches 69.1 mm	1.750	44.5	1.875	47.6	30	VT-6320-30C
		1.875	47.6	1.937	49.2	31	VT-6320-31C
		0.875	22.2	1.000	25.4	16	VT-6324-16C
		1.000	25.4	1.125	28.6	18	VT-6324-18C
		1.125	28.6	1.250	31.8	20	VT-6324-20C
		1.250	31.8	1.375	34.9	22	VT-6324-22C
		1.375	34.9	1.500	38.1	24	VT-6324-24C
		1.500	38.1	1.625	41.3	26	VT-6324-26C
		1.625	41.3	1.750	44.5	28	VT-6324-28C
		1.750	44.5	1.875	47.6	30	VT-6324-30C
28	3 5/32 inches 80.2 mm	1.875	47.6	2.000	50.8	32	VT-6324-32C
		2.000	50.8	2.125	54.0	34	VT-6324-34C
		2.125	54.0	2.250	57.2	36	VT-6324-36C
		2.250	57.2	2.375	60.3	38	VT-6324-38C
		2.375	60.3	2.437	61.9	39	VT-6324-39C
		1.375	34.9	1.500	38.1	24	VT-6328-24C
		1.500	38.1	1.625	41.3	26	VT-6328-26C
		1.625	41.3	1.750	44.5	28	VT-6328-28C
		1.750	44.5	1.875	47.6	30	VT-6328-30C
		1.875	47.6	2.000	50.8	32	VT-6328-32C
28	3 5/32 inches 80.2 mm	2.000	50.8	2.125	54.0	34	VT-6328-34C
		2.125	54.0	2.250	57.2	36	VT-6328-36C
		2.250	57.2	2.375	60.3	38	VT-6328-38C
		2.375	60.3	2.500	63.5	40	VT-6328-40C
		2.500	63.5	2.625	66.7	42	VT-6328-42C
		2.625	66.7	2.750	69.9	44	VT-6328-44C
		2.750	69.9	2.875	73.0	46	VT-6328-46C

*The cable diameter code is used to define the grommet size in the connector's catalog part number. For example, connector GD-1016-51PL-18 comes with a size "18" grommet, to be used with a cable diameter range of 1.00 – 1.125 inches (25.4 – 28.6 mm).

STEP 4 - TERMINATING CONDUCTORS

Terminate conductors (see detail) thru numbered insulation cavities per table below. Tighten set screw to value per table using the hex wrench provided.

CONTACT SIZE (AMPS)	HEX WRENCH SIZE (INCHES)	TORQUE	
		in-lb	N-m
10	5/64	15	1.70
30	3/32	26	2.94
60	1/8	26	2.94
100	5/32	70	7.91
200	3/16	120	13.56

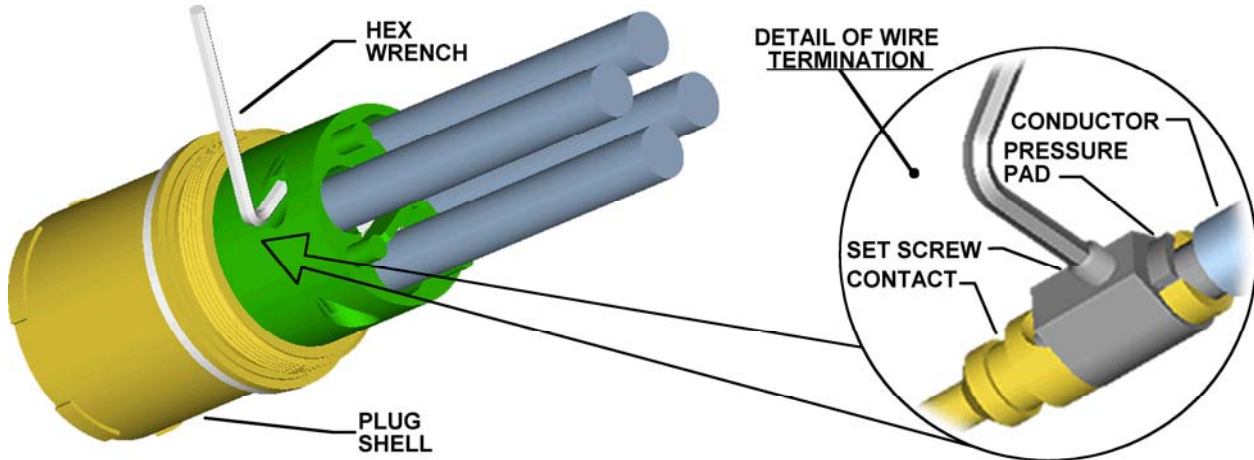

NOTE: Do not remove insert from plug shell.

NOTE: N'enlevez pas l'insertion de la coquille de prise.

STEP 5 - ASSEMBLING PLUG SHELL TO COUPLING SLEEVE

POSITION COUPLING SLEEVE ABOVE PLUG SHELL & INSERT ASSEMBLY AS SHOWN. APPLY DOWNWARD PRESSURE ON COUPLING SLEEVE ASSEMBLY TO DRIVE INTERNAL GARTER SPRING OVER SHOULDER ON PLUG SHELL. PLUG SHELL IS NOW CAPTIVE WITHIN THE COUPLING SLEEVE ASSEMBLY AND ABLE TO ENGAGE THE CABLE HOUSING ASSEMBLY (SEE STEP 6).

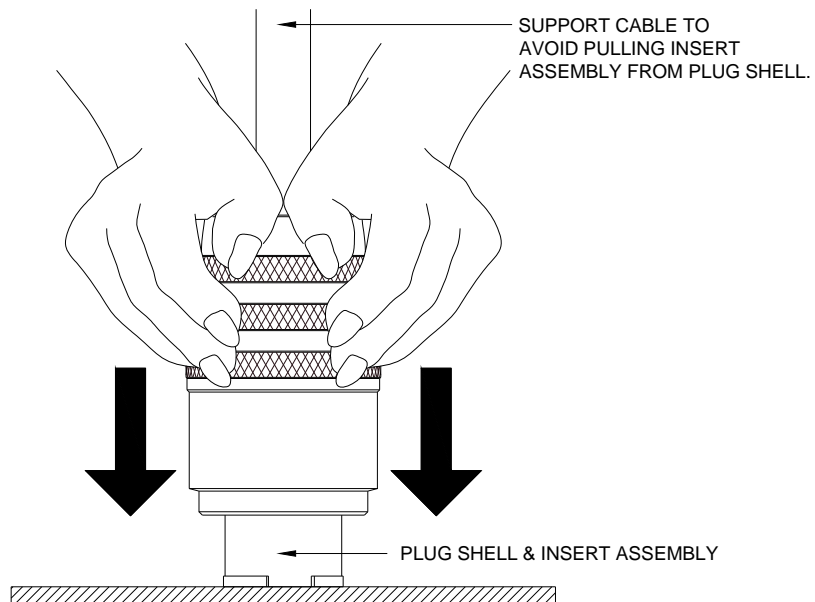

STEP 6 - ASSEMBLING CABLE HOUSING & PLUG SHELL ASSEMBLY

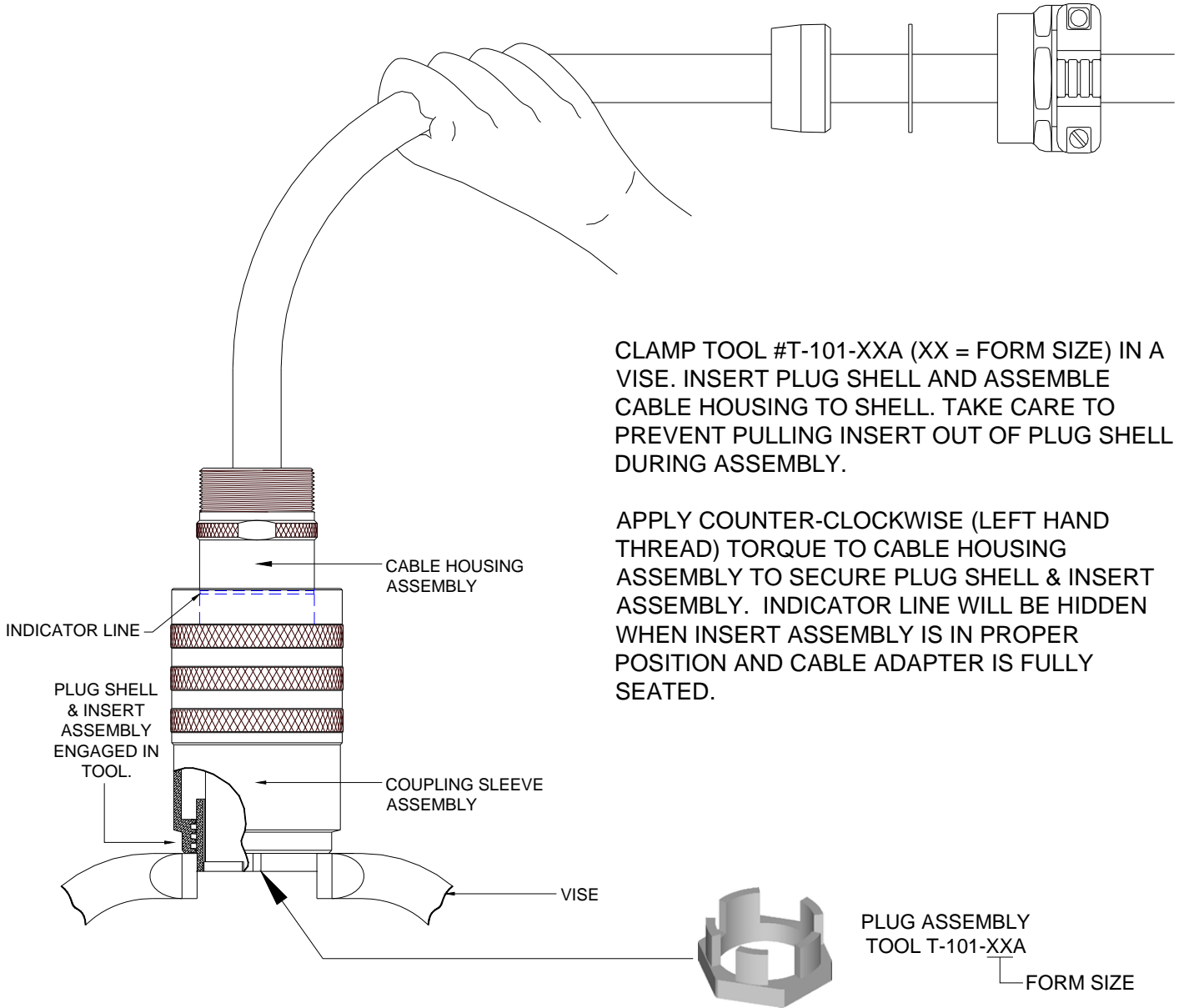

CLAMP TOOL #T-101-XXA (XX = FORM SIZE) IN A VISE. INSERT PLUG SHELL AND ASSEMBLE CABLE HOUSING TO SHELL. TAKE CARE TO PREVENT PULLING INSERT OUT OF PLUG SHELL DURING ASSEMBLY.

APPLY COUNTER-CLOCKWISE (LEFT HAND THREAD) TORQUE TO CABLE HOUSING ASSEMBLY TO SECURE PLUG SHELL & INSERT ASSEMBLY. INDICATOR LINE WILL BE HIDDEN WHEN INSERT ASSEMBLY IS IN PROPER POSITION AND CABLE ADAPTER IS FULLY SEATED.

STEP 7 - FINAL ASSEMBLY

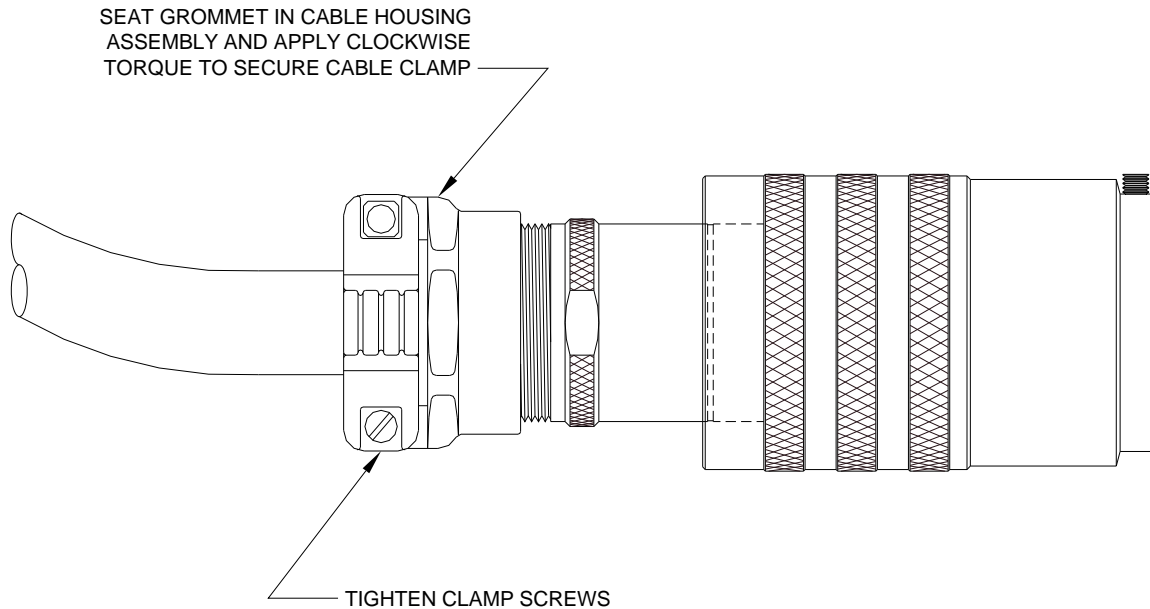

REMOVING PLUG SHELL, IF NECESSARY

Plug shell may be removed from the coupling sleeve by using tool TP-102-XXR (ordered separately) and proceeding as follows:

Disassemble steps.

Fix disassembly tool as described below. Insert plug shell / coupling sleeve assembly onto disassembly tool so that plug shell keys enter tool body. Rotate plug shell so that keys engage the perimeter slot within the disassembly tool body. Pull coupling sleeve assembly from disassembly tool to disengage from plug shell.

To fix disassembly tool to perform operation described above: Option A - Remove tool rod, and fix tool body in a bench vise. Option B - With rod in place as shown, set tool on floor. Secure tool assembly by holding ends of the rod to the floor.

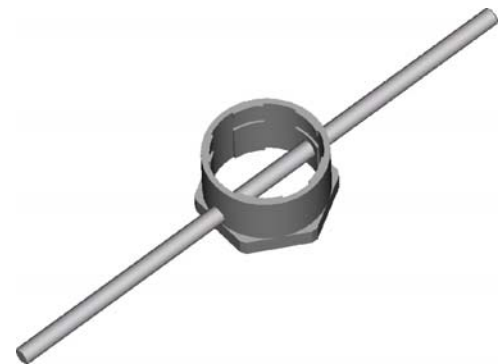

**DISASSEMBLY TOOL
T-102-XXR**

Note: T-102-XXR can be used in place of T-101-XXA to hold the plug shell when assembling the cable housing. (illustrated above.)

Usage Instructions

1. **Engaging plug to receptacle:** Align plug keys to receptacle keyways and turn coupling sleeve clockwise. Plug will be injected automatically & close circuit. Continue turning coupling sleeve to solid to provide environmental seal. Caution: Do not interfere with cable housing.
2. **Disengaging plug to receptacle:** Rotate coupling sleeve counter-clockwise. Plug will eject automatically. Continue turning coupling sleeve to extract the plug. Caution: Do not interfere with cable housing.
3. **Caution:** To prevent shock hazard, replace receptacle cover when not in use.
Attention: Pour empêcher le risque de choc, remplacez la couverture de réceptacle quand pas en service.

Maintenance and Inspection

1. When conditions require, lubricate coupling threads with silicone oil, Vantage Part Number VT-9400-21D.
2. Periodically inspect plug to insure that all thread engagements are secure and that the grommet continues to provide an environmental seal.
3. Periodically inspect plug for excessive wear. Consult Vantage with any questions regarding repair or replacement.

Note: Electrical installation shall be in compliance with the National Electric Code (NEC), EN/IEC60079-14, and/or any other presiding local or national electrical codes.

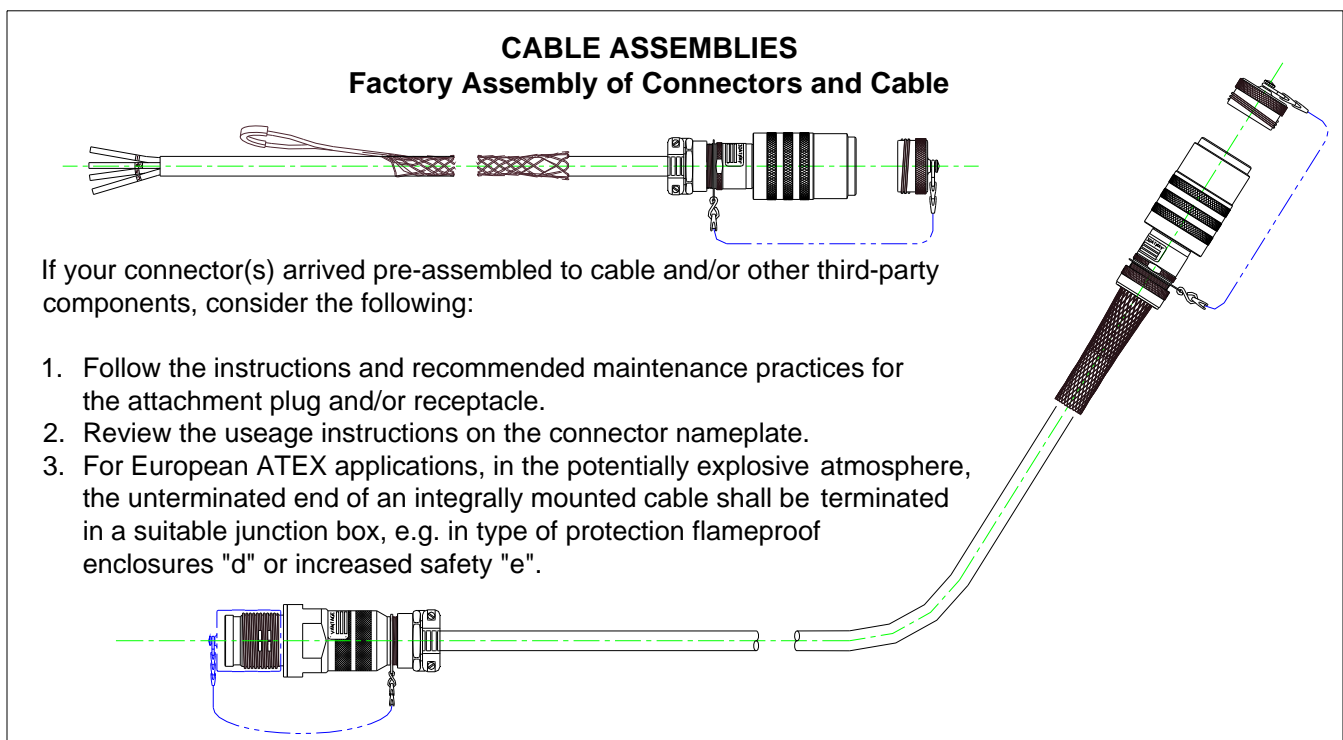

4675 South Windermere Street
Englewood, Colorado 80110, USA

Voice 303-761-2121
FAX 303-789-4215
E-mail support@VantageXP.com
Web Site www.VantageXP.com